

TOOLS REQUIRED

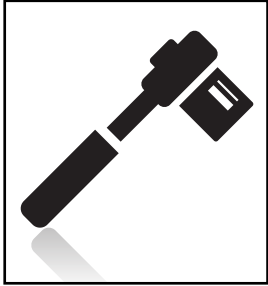

1/2" & 9/16" SOCKET WRENCH

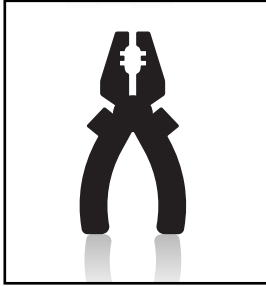

PLIERS

NOTE:

ONCE YOU HAVE FINISHED THE SPOT SPRAYER AND TRAILER ASSEMBLY, MOVE ON TO THE BOOM ASSEMBLY CARD, TO COMPLETE YOUR SPRAYER.

Adjustable Hitch (1) 32-100066	Boom Mount (1) 32-100103	QA Boom Post (1) 32-100104	Tongue (1) 32-100106	Hitch Clamp (1) 31-100510	Hitch Pin (2) 722HP
Wheel (2) TWA16X6.50-8/1"	Axle (1) 32-100100	Hair Pin (2) P-7925	5/16" - 1" Hex Bolt (4) 33-100116	Washer (4) 33-100115	5/16" Flange Nut (4) 33-100113
3/8" Push Nut (1) 33-100041	Knob (1) 33-100040	2.75" Carriage Bolt (1) 33-100039	3/8" Hex Nut (2) 33-100125	3/8" - 1" Hex Bolt (2) 33-200020	Cotter Pins (2) 33-100127

1.

PARTS



TOOLS

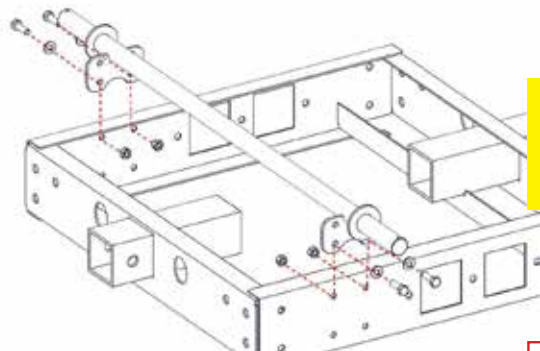

NOTE: When putting frame and tank upside down, be careful not to damage pump and hose.

Attaches Axle to Frame

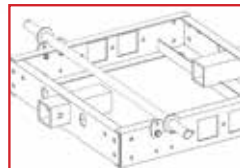

Turn frame and tank upside down, position the Axle on the bottom of the FlexFrame as shown above.

Align holes in axle plate with FlexFrame. Secure with 5/16" - 1" Hex Bolts and Flange Nuts. Tighten securely with Socket Wrench.

2.

PARTS



TOOLS

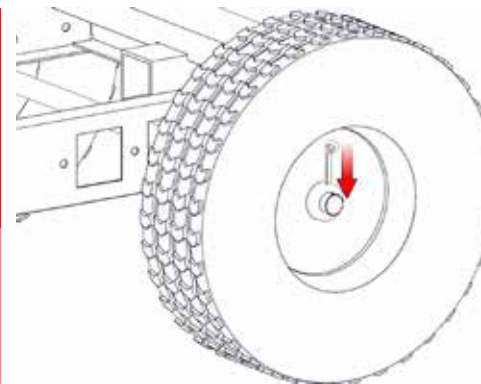

Insert Cotter Pin, then bend the ends out with Pliers.

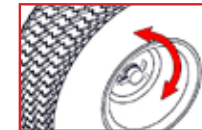

Attaches Wheels to Axle

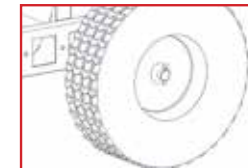

Slide Wheels over Axle making sure Valve Stems are facing out away from the FlexFrame.

Insert Cotter Pins through the holes on each Axle. Use Pliers to bend the ends of the Cotter Pins, to ensure the Wheels can't slide off the Axles.

3.

PARTS



TOOLS



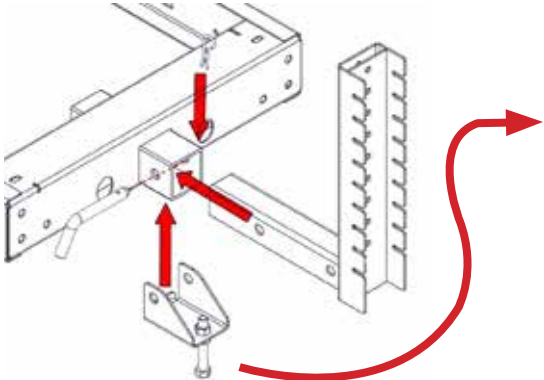

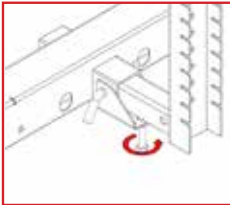

With Socket Wrench, tighten the bolt on the underside of the Hitch Clamp until the QA Boom Post is secure and no longer moves.

Attaches QA Boom Post to Frame

Insert QA Boom Post into the open 2" Receiver. Align holes with 2" Receiver and QA Boom Post.

Insert Hitch Pin through the holes between Receiver and QA Boom Post. Secure Hitch Pin with Hair Pin.

4.

PARTS

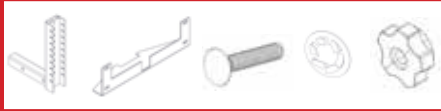

TOOLS



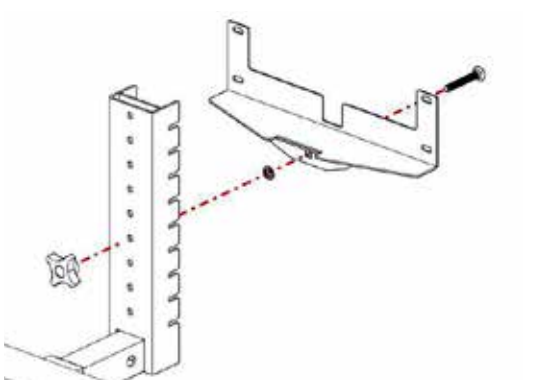

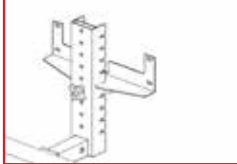

NOTE: Boom Mount can be adjusted to other open slots on the QA Boom for the ideal broadcast spray height.

Attaches Boom Mount to QA Boom Post

Insert and secure the 2.75" Carriage Bolt to the Boom Mount with the 3/8" Push Nut.

Slide Boom Mount into one of the open slots on QA Boom Post and slide 2.75" Carriage Bolt through open hole on QA Boom Post. Thread on Knob to 2.75" Carriage Bolt.

5.

PARTS



TOOLS



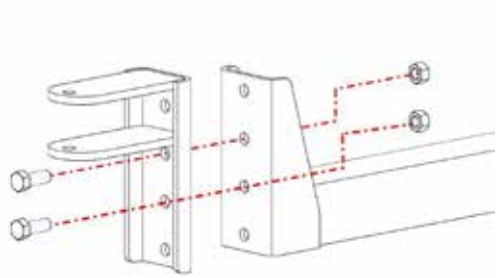

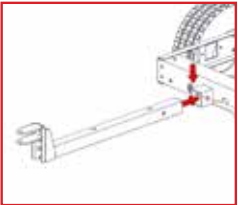

Secure the Tongue into a receiver on the Flexframe with a Hitch Pin and Hair Pin.

Attaches Adjustable Hitch to Tongue

Align the holes on the Adjustable Hitch and Tongue.

Insert 3/8" - 1" Hex Bolts and tighten with 3/8" Hex Nuts with Socket Wrench.

B.

BREAKDOWN

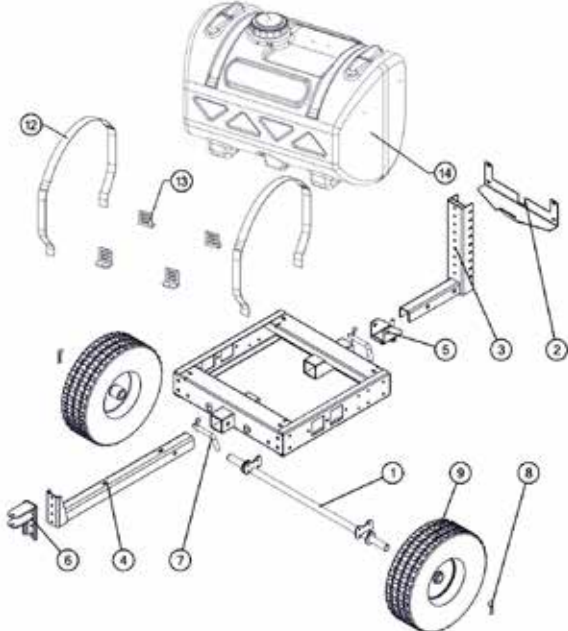

ID	Part Number	Description	Qty
1	32-100100	Axle	1
2	32-100103	Boom Mount	1
3	32-100104	QA Boom Post	1
4	32-100106	Tongue	1
5	34-140191	Hitch Clamp	1
6	32-100066	Adjustable Hitch	1
7	722HP	Hitch Pin	2
8	33-100127	Cotter Pin	2
9	TWA16X6.50-8/1"	Wheel	2
10	32-100107	FlexFrame Mount	1
11	P-7925	Hair Pin	2
12	TDS1.5-67	Tank Strap	2
13	TD-150	Tank Strap Mount	4
14		Sprayer Tank	1