

123 Industrial Loop Road
Paynesville, MN 56362
Phone: 1-800-864-1649
www.master-mfg.com



MASTER
MANUFACTURING

40 & 60 GALLON UTILITY SPRAYER



Rev 1 Jan 2009

INTRODUCTION

The purpose of this manual is to assist you in the assembly, operation and maintenance of your sprayer or accessories. Please read through this manual completely too fully understand how to operate and maintain your equipment. This product has been manufactured to provide years of dependable service; proper operation and maintenance will ensure its dependability. Keep your manual in a safe, convenient place for future reference. Always mention the model and part number in any correspondence.

ASSEMBLY

The 40 & 60 gallon Utility Sprayers come partially assembled. Please read the following directions fully before beginning the assembly process. Refer to assembly drawings figures 1-6 for reference.

Control Post Assembly

- 1.) Remove components from carton.
- 2.) Place skid frame and tank on flat surface
- 3.) Position Control post (PN 32-100051) on either end of the skid frame and fasten with two 5/16-18 x 1" cap screws (PN 33-100116) and two 5/16"-18 nuts (PN 33-100113). **Figure #2**
- 4.) Attach Boom Mount (PN 32-100063) to back end of skid frame using four 5/16-18" x 1" cap screws (PN 33-100116) and four 5/16-18" nuts (PN 33-100113). **Figure #3.**
- 5.) **Optional** - Attach Boom Mount (PN 32-100063) to side of skid frame using two 5/16-18" x 1" cap screws (PN 33-100116) and two 5/16-18" nuts (PN 33-100113).

Frame Assembly

- 6.) The UTV boom mount can be mounted on the end or the side of the Skid Frame. Determine which location will work best for your application.
- 7.) Position the UTV boom mount (PN 32-100063) on the side of the frame chosen in step one and fasten with two 5/16-18 x 1" bolts (PN 33-103116) and 5/16' serrated nuts (PN 33-103116).
- 8.) Attach angle brackets (PN 31-100139) to UTV boom mount with four 5/16-18 x 1" bolts (PN 33-103116) and 5/16' serrated nuts (PN 33-103116).
- 9.) Adjust angle brackets to allow clearance for boom from back of UTV.

Spray Boom Attachment

- 1.) Extend the Ten foot boom on a flat surface and remove the two loose bolts located on the end of the center boom section. Position the hinge over the holes in the center boom section and place bolts through holes. Tighten the bolt securely but ensure the hinge moves freely in both directions. **Figure #4.**
- 2.) Attach two extension springs (PN 33-100117) to center boom spring mount and eye bolt located on boom. **Figure #4.**
- 3.) Attach the two upright spray boom brackets (PN 31-100160) to the boom mount using the four 5/16-18 x 1 bolts (PN 33-100116) and four 5/16 nuts (PN 33-100113). **Figure #6.**
- 4.) Attach the 10' spray boom (PN 34-140059) to the upright spray boom brackets using two 5/16-18 x 1 bolts (PN 33-100116) and two 5/16 nuts (PN 33-100113). **Figure #6.**
- 5.) Attach the boom hose to the manifold valve located on the pump and tighten securely.
- 6.) Remove nozzle nuts from boom and insert deflector spray nozzle facing down. Re-assembly nozzle nuts. Ensure nozzle spacing is set to 40 inches. Re-adjust if necessary.
- 7.) Optimum boom height is 14 to 15 inches above area to be sprayed. Use the location holes in the upright spray boom brackets as adjustments to obtain the optimum spray height.

Wiring Harness

- 1.) Attach the wiring harness with inline switch to the sprayer pump by pushing the two terminal connectors together.

- 2.) Refer to vehicle manual to locate battery and attach wiring harness leads to battery. Ensure Red lead attaches to Positive (+) side of battery and black lead connects to Negative (-) side of battery.

Spray Gun & Gauge

- 1.) Attach spray gun to manifold by pushing over 3/8" hose barb and fasten with hose clamp (PN SHC-F). **Figure #1.**
- 2.) Apply thread sealant to gauge threads and screw gauge into manifold.

OPERATION

Using the 10' boom

- ∞ Four things must be considered before spraying with the boom.
 1. How much chemical must be mixed in the tank?
 2. Rate of spray (gallons per acre to be sprayed.)
 3. What pressure (P.S.I) will be used.
 4. Speed traveled (M.P.H.) while spraying.
- ∞ Refer to the chemical label to determine the chemical mixture.
- ∞ See the tip chart to determine the pressure to be used. The chart will also show the speed used when spraying.
- ∞ Open the valve lever to the boom nozzles.
- ∞ Check the spray pattern. Usually you can see the coverage better on solid concrete surface, such as a driveway.
- ∞ Raise or lower the boom to achieve a good coverage pattern. If you can see dry spots on the concrete surface you will need to raise the boom. Too much solution in the pattern areas means you need to lower the boom. Generally the proper height will be from 13 inches to 18 inches from the area to be sprayed.

Operation

The nozzles on the boom will spray approximately a 120" wide pattern. The nozzle height should be set approximately 15" above the object being sprayed.

Once you know how much you are going to spray then determine (from the tip chart) the spraying pressure (PSI) and the spraying speed (MPH). The pressure can be set by running the sprayer with the boom nozzles "ON" and then by adjusting the garden hose valve lever (valve with hose returning to tank) until the gauge reads the desired pressure. Notice that the pressure will go up when the garden hose valve is slowly closed.

When selecting pressure from the tip chart, it is a good idea to try for the 20 or 30 PSI range as this allows an excellent nozzle pattern. At 10 PSI the pattern begins to break up and at 40 PSI you may notice some drift. Conditions of weather and terrain must be considered when setting the sprayer. Do not spray on windy days. Protective clothing must be worn in some cases. Be sure to read the chemical label carefully.

After all calibrations have been completed, add water and chemical to the tank. Always follow chemical manufacturer's instructions for mixing.

CLEANING & STORAGE

Most spray materials are highly corrosive. The most important aspect of long dependable service from the sprayer is a thorough cleaning immediately following each use. In addition, the residue of one type of chemical could cause an undesirable effect when a different chemical is used for a different purpose.

The most effective cleaning method is to pump several rinses of clean water through the tank, pump, hoses, boom, spray gun, etc. A neutralizing agent such as a solution of Nutra-Sol, a detergent or household ammonia as recommended by the chemical manufacturer can assist in removal of a persistent chemical. When the system is thoroughly cleaned, drain the tank, suction line, pump, hoses, etc.

The following steps should be followed for the maintenance and storage of your sprayer.

1. Wash and flush out sprayer after completion of each phase of your program. Flush out sprayer when changing chemicals if there is a possibility of the chemicals being incompatible. Use of a detergent is advisable if the chemical manufacturer does not make specific cleaning recommendations. Flush system completely, including nozzles. Never use metal objects to open clogged nozzles.
2. Clean sprayer thoroughly before storing at the end of the spraying season. Permanent type anti-freeze added to the final rinse will leave a rust inhibiting film in parts of the sprayer.

WARRANTY PARTS SERVICE

Products sold shall be warranted from defects in workmanship and material when used within the service and scope for which they were designed for a period of one year from date of purchase. Contact your distributor/ dealer for replacements parts or warranty work. Please have your original sales receipt or other proof of purchase date when requesting any warranty work. To ensure the correct parts are acquired always provide the model number of your sprayer/attachment and the part number and description obtained from the illustrated parts breakdown in this manual.

Warnings

Gallons per Acre, 40" spacing

Nozzle part #	PSI	Flow GPM	4mph	5mph	6mph	7mph	8mph	9mph	10mph
DF2.0 Red colored nozzle	15	0.24	8.9	7.1	5.9	5.1	4.5	4.0	3.6
	20	0.28	10.4	8.3	6.9	5.9	5.2	4.6	4.2
	30	0.35	13.0	10.4	8.7	7.4	6.5	5.8	5.2
	40	0.4	14.9	11.9	9.9	8.5	7.4	6.6	5.9
	60	0.49	18.2	14.6	12.1	10.4	9.1	8.1	7.3
DF2.5 Brown colored nozzle	15	0.31	11.5	9.2	7.7	6.6	5.8	5.1	4.6
	20	0.35	13.0	10.4	8.7	7.4	6.5	5.8	5.2
	30	0.43	16.0	12.8	10.6	9.1	8.0	7.1	6.4
	40	0.5	18.6	14.9	12.4	10.6	9.3	8.3	7.4
	60	0.61	22.6	18.1	15.1	12.9	11.3	10.1	9.1
DF3.0 Gray colored nozzle	15	0.37	13.7	11.0	9.2	7.8	6.9	6.1	5.5
	20	0.42	15.6	12.5	10.4	8.9	7.8	6.9	6.2
	30	0.52	19.3	15.4	12.9	11.0	9.7	8.6	7.7
	40	0.6	22.3	17.8	14.9	12.7	11.1	9.9	8.9
	60	0.73	27.1	21.7	18.1	15.5	13.6	12.0	10.8

Note: All GPA calculations above are per nozzle.

-  **Ensure all trailer bolts are securely tightened and tires are properly inflated before each use. Failure to do so may lead to injury.**

-  **Trailer total weight with filled tank must not exceed maximum towable weight limit set by manufacture of pulling vehicle. Refer to vehicle manufactures specifications. Failure to follow manufactures specifications may lead to injury or breakdown.**

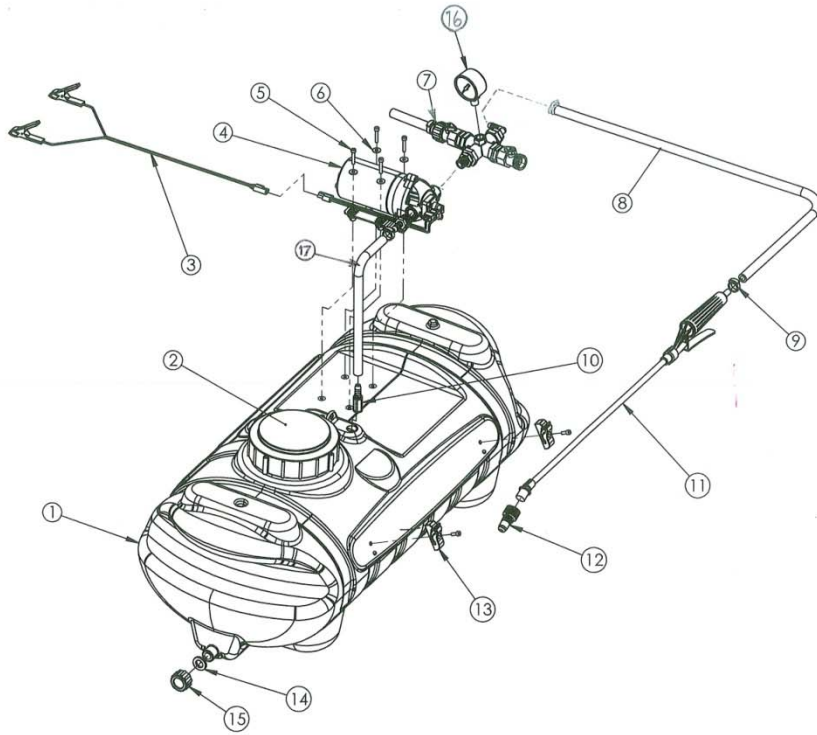

Figure #1
40 & 60 Gallon Tank Assembly

Ref	Qty	Part No.	Description
1	1	33-103245	Tank, 40 gallon
	1	33-103246	Tank, 60 gallon
2	1	33-103221	Lid, Tank
3	1	33-103233	Harness, Wire, SS, Switched
4	1	33-103232	Pump, Shurflo, 1.8gpm
	1	33-103205	Pump, Delavan, 3.0 GPM
	1	33-103209	Pump, Delavan, 2 GPM
5	4	33-103127	Screw, Machine, 10-24 x 1"
6	4	33-103131	Washer #10
7	2	34-140068	Manifold
8	15 ft	3204-1407	Hose, rubber, 3/8"
9	3	SHC-F	Clamp, hose
10	1	33-103121	Strainer, Inlet
11	1	SG-4507F	Gun, Spray, with filter
		SG-2218-18	Gun, Deluxe
12	1	SG-45ASSY-18	Nozzle, Assembly
13	1	GC-100-KIT	Clip, Gun (Pair)
14	1	W406-V	Washer, Garden Hose
15	1	33-103218	Cap, Garden Hose
16	1	1124DAB100	Gauge, 2", 0-160 psi

17	28"	3204-1407	Hose, rubber, 3/8" X 28" Inlet to pump, 40 Gallon
	36"	3204-1407	Hose, rubber, 3/8" X 36" Inlet to pump, 60 Gallon

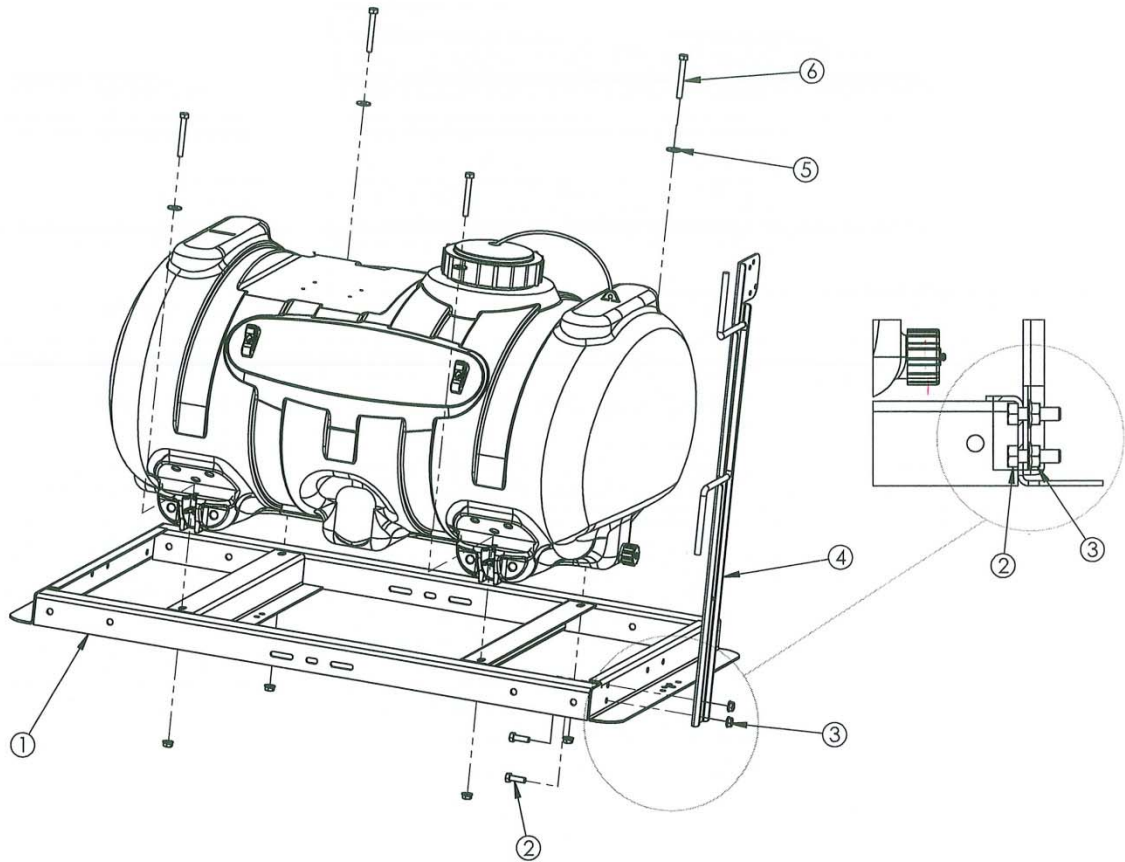

Figure #2
40 & 60 Gallon Tank to Frame Assembly

Item No.	Part Number	Description	Qty.
1	32-100060	Frame, Skid, 40 & 60 Gallon	1
2	33-100116	Screw, cap, 5/16-18 x 1"	2
3	33-100113	Nut, 5/16-18, serrated	6
4	32-100051	Control Post	1
5	33-100115	Washer, 5/16"	8
6	33-100122	Screw, Cap, 5/16-18 x 3"	4

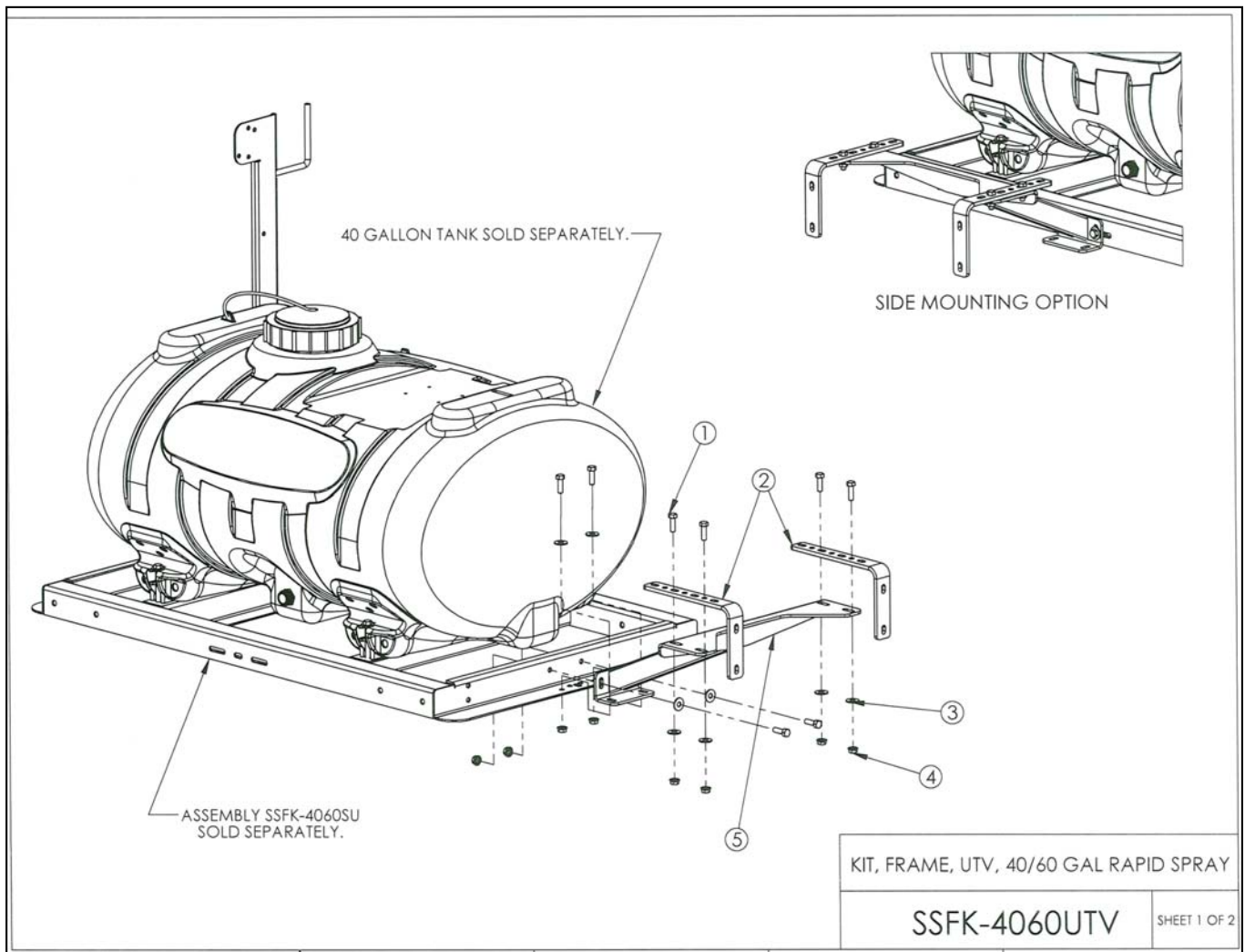

Figure #3
Boom mount

Item No.	Part Number	Description	Qty.
1	32-100063	Mount, boom	1
2	31-100139	Bracket, angle	2
3	33-100116	Screw, Cap, 5/16-18 x 1"	8
4	33-100113	Nut, 5/16-18, serrated	8
5	33-100115	Washer, 5/16"	8

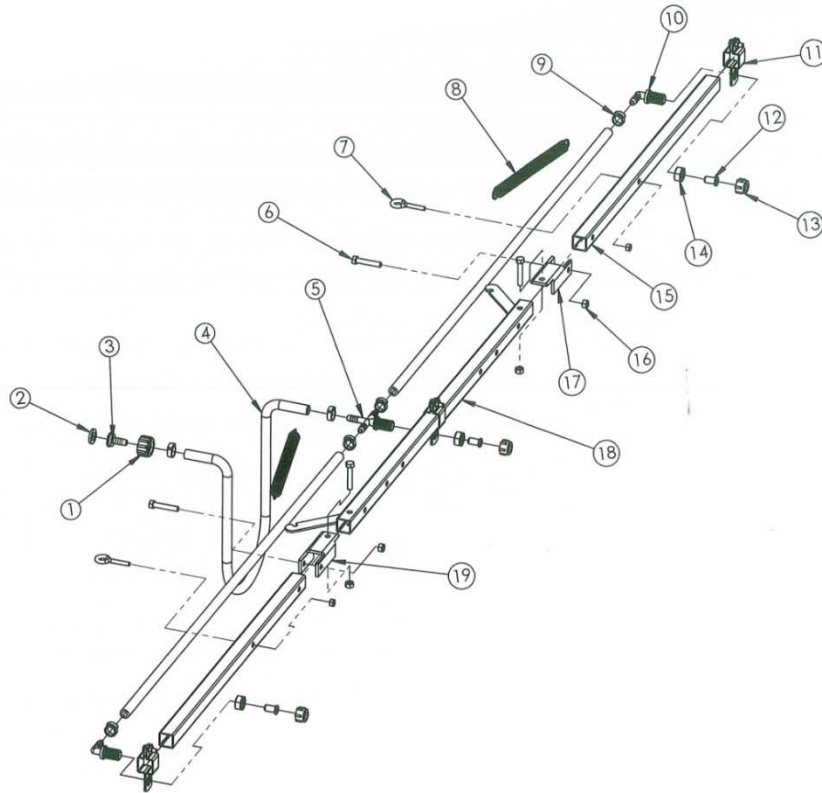
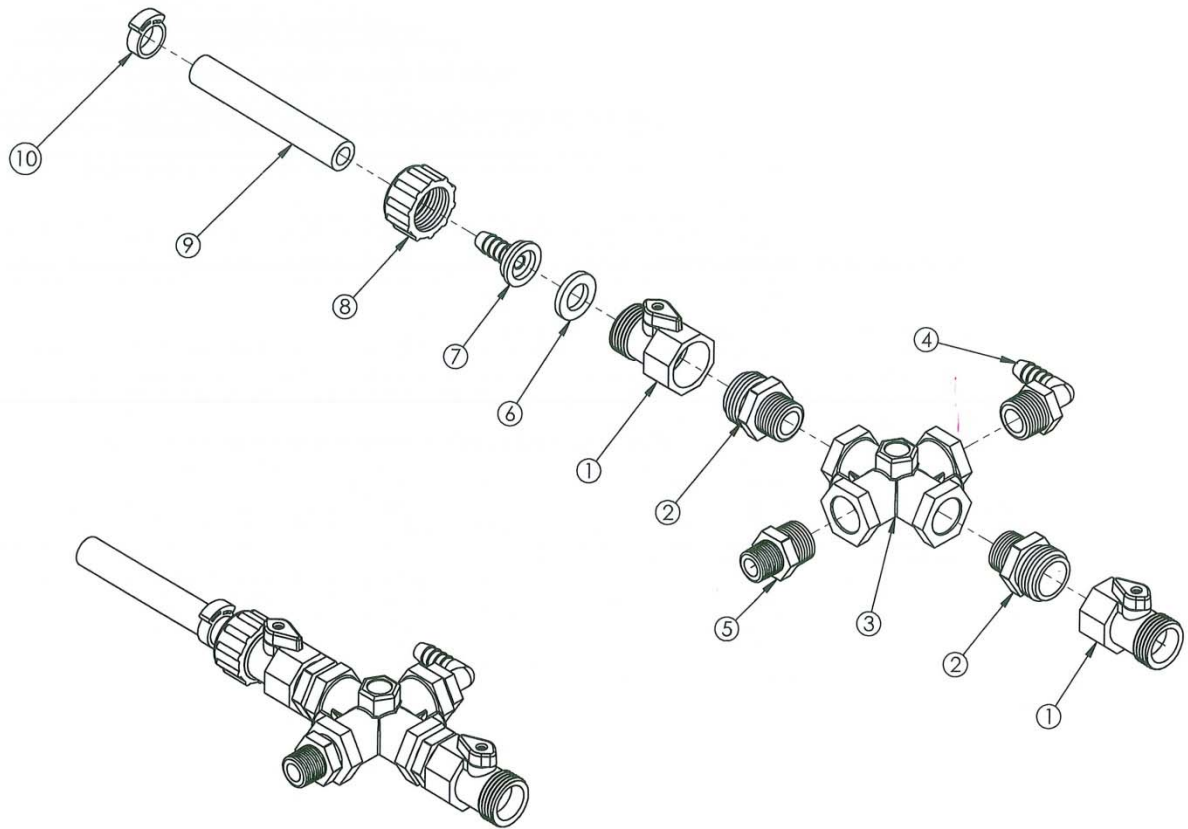

Figure #4
10' Boom Assembly

Item #	Part Number	Qty	Description
1	B34	1	Swivel Garden hose nut
2	W406V	1	Garden Hose washer
3	C38	1	Flat seat 3/8" hose barb
4	3204-1407	3	3/8" Rubber hose x 40"
5	T38C-C	1	3/8" cross nozzle body
6	33-100119	4	Bolt 5/16-18 x 1.75"
7	33-100118	2	Eye bolt, 1/4" x 1.5"
8	33-100117	2	Spring, Extension
9	SHC-F	6	Snapper hose clamp
10	NTL38-C	2	3/8" EL nozzle body
11	BCS-100	3	Boom clamp 1" sq
12	NS-50	3	Nozzle strainer, 50 mesh
13	8027	3	Nozzle nut
14	B12	3	Nozzle body nut
15	31-100136	2	Left and right 10' boom wing
16	33-100120	4	Lock nut 5/16-18
17	31-100137-R	1	Hinge, right
18	32-100021	1	Boom center section
19	31-100137-L	1	Hinge, left



**Figure #5
Manifold Assembly**

Item #	Part Number	Qty	Description
1	GHV-1-BLK	2	Valve, Garden Hose
2	E3412	2	Adaptor, 1/2" MNPT x 3/4" garden hose thread
3	GCR1214	1	Cross, 1/2" FMPT, 1/4" FNPT
4	EL1238	1	Elbow, 1/2" MNPT x 3/8" HB
5	M1238	1	Adaptor, 1/2" MNPT x 3/8" MNPT
6	W406V	1	Garden Hose Washer
7	C38	1	Flat seat 3/8" hose barb
8	B34	1	Swivel Garden Hose Nut
9	3204-1407	12"	Gates 3/8" Rubber Hose
10	SHC-F	1	Hose clamp

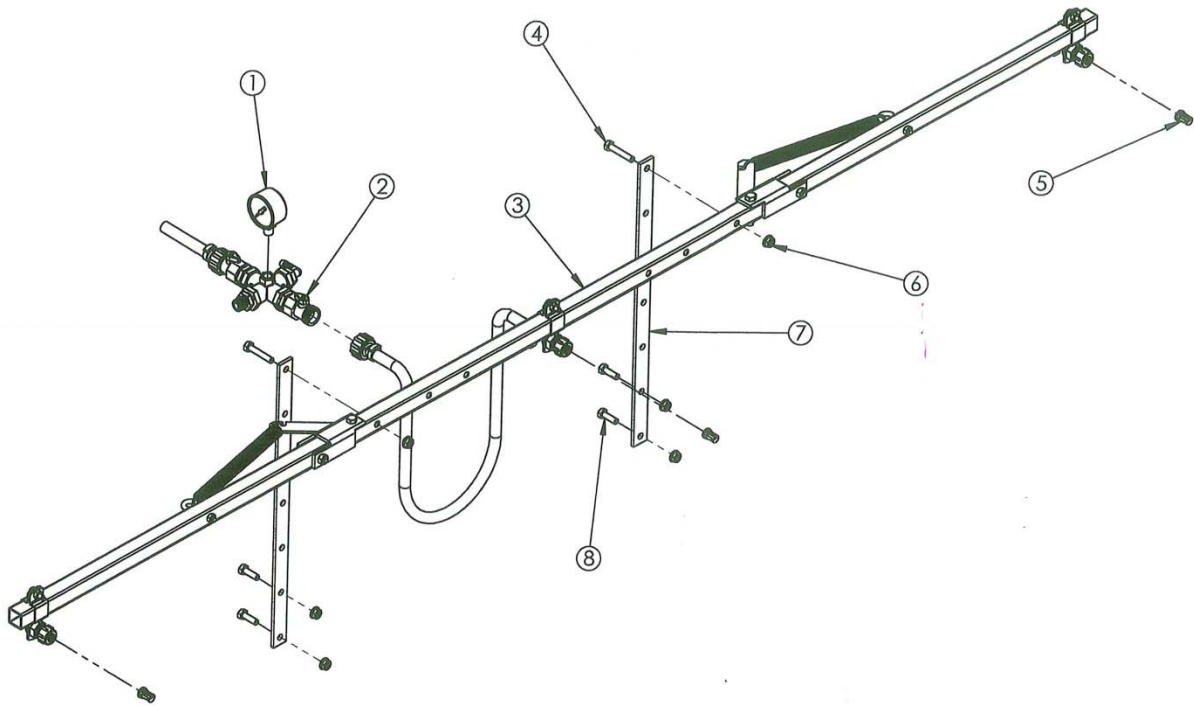

Figure #6
Boom Mount Assembly

Item #	Part Number	Qty	Description
1	1124DAB100	1	Gauge, 100 psi
2	34-140067	1	Assy, manifold
3	34-140059	1	Assy, 10' folding boom
4	33-100119	2	Bolt, 5/16-18 x 1.75
5	DF2.5	3	Spray nozzle, 2.5 brown
6	33-100113	6	Nut 5/16, serrated
7	31-100160	2	Bracket, vertical adjustment
8	33-100116	4	Bolt, 5/16-18 x 1